

GASPARDO

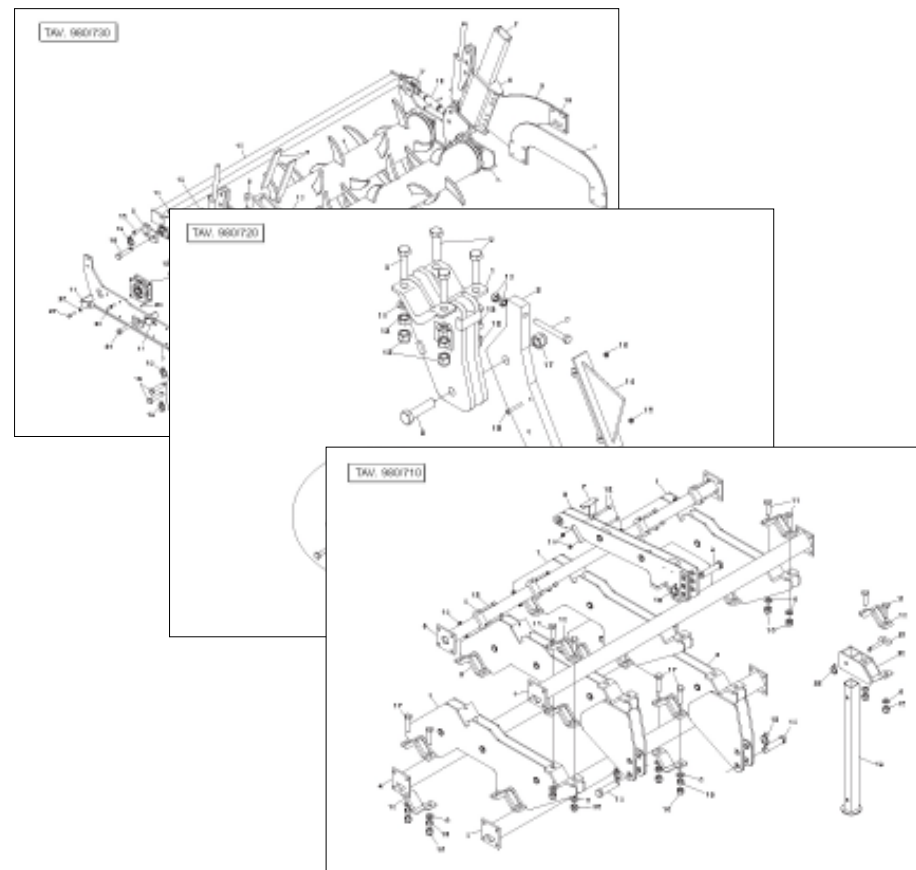

ARTIGLIO

Cod: 19530481 02.2004

GASPARDO

- IT** PARTI DI RICAMBIO
- GB** SPARE PARTS
- DE** ERSATZTEILE
- FR** PIÈCES DÉTACHÉES
- ES** PIEZAS DE REPUESTO

ITALIANO	ENGLISH	DEUTSCH	FRANÇAIS	ESPAÑOL
PARTI DI RICAMBIO	SPARE PARTS	ERSATZTEILE	PIECES DÉTACHÉES	RESPUESTOS
<p>Le ordinazioni delle parti di ricambio vanno fatte presso i nostri concessionari di zona e devono essere sempre corredate dalle seguenti indicazioni:</p> <ul style="list-style-type: none"> - Tipo, modello e numero di matricola dell'attrezzatura. Tali dati sono stampigliati nell'apposita targhetta di cui è dotata ogni attrezzatura. - Numero di codice della parte richiesta rilevabile dal catalogo ricambi. - Descrizione del particolare e quantità richiesta. - Numero della tavola. - Mezzo di trasporto. Nel caso questa voce non sia specificata, la Ditta Costruttrice, pur dedicando a questo servizio una particolare cura, non risponde di eventuali ritardi di spedizione dovuti a cause di forza maggiore. Le spese di trasporto si intendono sempre a carico del destinatario. La merce viaggia a rischio e pericolo del committente anche se venduta franco destino. <p>NOTA: Il termine (Dx) Destro o (Sx) Sinistro della macchina o di parti di essa, è inteso guardando la macchina dalla parte posteriore. Le eccezioni saranno indicate.</p>	<p><i>Orders must be transmitted through our area dealers and should always include the following indications:</i></p> <ul style="list-style-type: none"> - Type, model and serial number of the machine. <i>These data are punched on the data plate with which every implement is equipped.</i> - Code number of the required spare part. <i>This will be found in the spare parts catalogue.</i> - Description of the part and required quantity. - Table number. - Means of dispatch. <i>If this item is not indicated, the Manufacturer, while dedicating particular care to this service, shall not be held responsible for delays in delivery caused by cases of force majeure. Transport expenses shall always be at the consignee's charge. The goods travel at the purchaser's risk and peril even when sold ex destination.</i> <p>NOTE: <i>The symbols (Dx) right and (Sx) left, concerning the machine or single parts of it, are referred, as in the figure, to a rear view of them. Exceptions will be indicated.</i></p>	<p>Die Bestellungen müssen bei unseren Gebietshändlern aufgegeben werden. Bei der Bestellung sind stets die folgenden Angaben zu machen:</p> <ul style="list-style-type: none"> - Typ, Modell und Serien-Nummer des Geräts. Diese Daten stehen auf dem Typenschild, mit dem jedes Gerät versehen ist. - Artikel Nr. der erforderlichen Ersatzteile. Diese stehen im Ersatzteil-Katalog. - Beschreibung des Ersatzteils und die erforderliche Stückzahl. - Tafelnummer. - Versandmittel. Wenn dieser Punkt nicht spezifiziert wird, haftet die Herstellerfirma nicht für etwaigen Lieferverzug aufgrund höherer Gewalt, auch wenn er diesen Service besonders aufmerksam abwickelt. Die Frachtkosten gehen dagegen immer zu Lasten des Empfängers. Die Ware reist auf Gefahr und Risiko des Auftraggebers, auch wenn frei Haus Verkauft vereinbart worden ist. <p>N.B.: Die Merkzeichen (Dx) rechts und (Sx) links betreffen eine rückwärtige Aussicht der Maschine oder Teile von ihr (siehe Bild). Ausnahmen werden gezeigt.</p>	<p><i>Les ordres doivent être effectués auprès de nos concessionaires de zone en précisant les indications suivantes:</i></p> <ul style="list-style-type: none"> - Type, modèle et numéro de série de la machine. <i>Ces données sont gravées sur la plaque d'identification de chaque outil.</i> - Numéro de code de la pièce détachée indiqué sur le catalogue des pièces détachées. - Description de la pièce et quantité requise. - Numéro de plan. - Moyen d'expédition. <i>Si cette rubrique n'est pas indiquée, le Constructeur, bien que soucieux de ce service, ne répond pas des retards d'expédition pour des causes de force majeure. Les frais de transport sont toujours à la charge du destinataire. La marchandise voyage aux risques et périls de l'acheteur même si vendue franco de port.</i> <p>N.B.: <i>Les références (Dx) droit et (Sx) gauche de la machine ou des parties de la même, est entendue, comme de la figure, en regardant la machine de derriere dans le sens de marche.</i></p>	<p>Los pedidos han de efectuarse en nuestros concesionarios de zona y deben incluir siempre las siguientes indicaciones:</p> <ul style="list-style-type: none"> - Tipo, modelo y número de matrícula del equipo. Dichos datos están impresos en la relativa placa presente en el equipo. - Número de código de la parte requerida presente en el catálogo respuestas. - Descripción de la pieza y cantidad requerida. - Numero de ilustración. - Medio de transporte. En caso que este ítem no esté especificado, el Fabricante, aún prestando la debidas consideraciones para este aspecto, no responde por eventuales retardos de env'o debidos a causas de fuerza mayor. Los gastos de transporte se consideran siempre a cargo del destinatario. La mercadería viaja bajo riesgo y peligro del comprador, incluso cuando se vende franco destino. <p>N.B.: La refencia (Dx) derecha o (Sx) izquierda de la máquina o de sus componentes, se entiende, como en la figura, mirando la máquina por la parte trasera. Se indicarán las excepciones.</p>

INDICE DELLE TAVOLE - *TABLE INDEX* - VERZEICHNIS DER TAFELN - *INDEX DES PLANS* - INDICE ILUSTRACIONES

<i>N° Tavola</i>	<i>Descrizione</i>	<i>Pagina</i>
TAV. 980/711	Telaio	4
TAV. 980/721	Ancore	6
TAV. 980/731	Doppio rullo posteriore	8
TAV. 980/740	Impianto oleodinamico rulli posteriori	10
TAV. 980/751	Bandinelle laterali	12
TAV. 980/760	Dischi di contenimento	14
TAV. 980/770	Regolazione meccanica rulli	16

TAV. 980/711

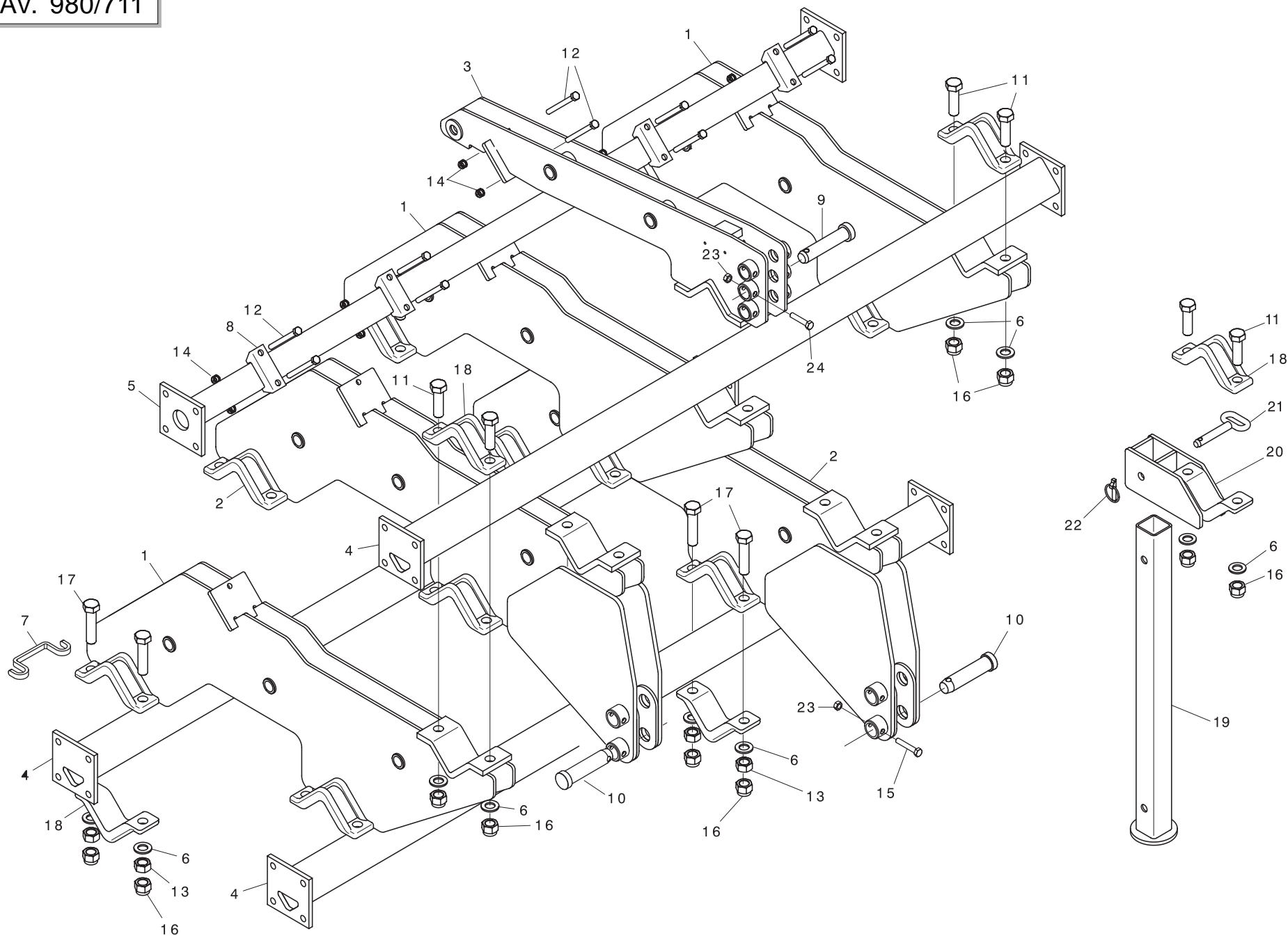

TELAIO

TAV. 980/711

Pos.	Cod.	Descrizione	Description	Description	Benennung	Descripcion
1	17810011	SUPPORTO TELAIO	FRAME SUPPORT	SUPPORT CH-SSIS	RAHMENHALTERUNG	SOPORTE BASTIDOR
2	17810073	SUPPORTO TELAIO	FRAME SUPPORT	SUPPORT CH-SSIS	RAHMENHALTERUNG	SOPORTE BASTIDOR
3	17810112	SUPPORTO TELAIO	FRAME SUPPORT	SUPPORT CH-SSIS	RAHMENHALTERUNG	SOPORTE BASTIDOR
4	17810460	TELAIO ANTERIORE 300	FRAME FRONT 300	BATI AVANT 300	VORDERRAHMEN 300	BASTIDOR DELANTERO 300
4	17810140	TELAIO ANTERIORE 250	FRAME FRONT 250	BATI AVANT 250	VORDERRAHMEN 250	BASTIDOR DELANTERO 250
5	17810481	TELAIO POSTERIORE 300	MAIN FRAME 300	BATI ARRIERE 300	HINTERRAHMEN 300	BASTIDOR TRASERO 300
5	17810171	TELAIO POSTERIORE 250	MAIN FRAME 250	BATI ARRIERE 250	HINTERRAHMEN 250	BASTIDOR TRASERO 250
6	18701590	RONDELLA 25 x 35 x2,5 ZN	WASHER 25 x 35 x2,5 ZN	RONDELLE 25 x 35 x2,5 ZN	UNTERLEGSCHEIBE 25 x 35 x2,5 ZN	ARANDELA 25 x 35 x2,5 ZN
7	17812200	LAMA INTERPOSIZIONE SCONTRI ZN	BLADE	LAME	MESSER	CUCHILLA
8	16740160	SCONTRO A U SP.8 2F13 83	U-SHAPED STOP TEETH B343SP.8 2	BUT+E EN U EP.8 2F13 83	U-ANSCHLAG SP.8 2F13 83	DIENTE DE PARADA A U ESP.8 2F1
9	15316010	SPINA GASPARDO 32X134 ZN	GASPARDO PIN 32X134 ZN	BROCHE GASPARDO 32X134 ZN	STIFT GASPARDO 32X134 ZN	CLAVIJA GASPARDO 32X134 ZN
10	15316020	SPINA GASPARDO 36X134 ZN	GASPARDO PIN 36X134 ZN	BROCHE GASPARDO 36X134 ZN	STIFT GASPARDO 36X134 ZN	CLAVIJA GASPARDO 36X134 ZN
11	41602193	VITE 24X 80 5737 10.9 ZN	BOLT 24X80 5737 10.9G GALVANIZ	VIS 24X80 5737 10.9G ZN	SCHRAUBE 24X80 5737 10.9G ZN	TORNILLO 24X80 5737 10.9G ZN
12	41602127	VITE 12X120 5737 8.G ZN	BOLT 12X120 5737 8.G GALVANIZ.	VIS 12X120 5737 8.G ZN	SCHRAUBE 12X120 5737 8.G ZN	TORNILLO 12X120 5737 8.G ZN
13	43530014	DADO 24 5588 6.8 ZN	NUT 24 5588 6.8 ZN	+CROU 24 5588 6.8 ZN	MUTTER 24 5588 6.8 ZN	TUERCA 24 5588 6.8 ZN
14	43442007	DADO AUTOB.NOR.12 ZN	NORMAL SELF-LOCKING NUT 12 GAL	ECROU AUTOB. NOR. 12 ZN	SELBSTSP. MUTTER NOR.12 ZN	TUERCA AUTOB. NOR.12 ZN
15	41602060	VITE 12X70 5737 8.G ZN	BOLT 12X70 5737 8.G GALVANIZED	VIS 12X70 5737 8.G ZN	SCHRAUBE 12X70 5737 8.G ZN	TORNILLO 12X70 5737 8.G ZN
16	43442015	DADO AUTOB.NORM.24 ZN	SELF-LOCKING NUT NORM.24 ZN	+CROU AUTOB.NORM.24 ZN	SELBSTSPERR. MUTTER NORM.24 ZN	TUERCA AUTOB. NORM.24 ZN
17	41602191	VITE 24X100 5737 10.9 ZN	SCREW 24X100 5737 10.9 ZN	VIS 24X100 5737 10.9 ZN	SCHRAUBE 24X100 5737 10.9 ZN	TORNILLO 24X100 5737 10.9 ZN
18	17811170	SCONTRO PER TUBO 100	STRIKER PLATE 100	BUTEE 100	ANSCHLAG 100	ELEMENTO DE EMPALME 100
19	17810380	PUNTELLO	PROP	ETRESILLON	STÜTZE	PUNTAL
20	17810411	SUPPORTO PUNTELLO	PROP SUPPORT	SUPPORT ETRESILLON	STtZENHALTERUNG	SOPORTE PUNTAL
21	17810440	PERNO ZN	PIN ZN	PIVOT ZN	BOLZEN ZN	PERNO ZN
22	45965007	SPINA A SCATTO D 9 B/83	SNAP PIN D 9 B/83	FICHE A DETENTE D. 9 B/83	EINRASTSTIFT D 9 B/83	CLAVIJA DE MUELLE D 9 B/83
23	43549004	DADO TRISTOP M12	NUT- TRISTOP M12	ECROU TRISTOP M12	MUTTER TRISTOP M12	TUERCA TRISTOP M12
24	41602058	VITE 12X60 5737 8.G ZN	BOLT 12X60 5737 8.G GALVANIZED	VIS 12X60 5737 8.G ZN	SCHRAUBE 12X60 5737 8.G ZN	TORNILLO 12X60 5737 8.G ZN

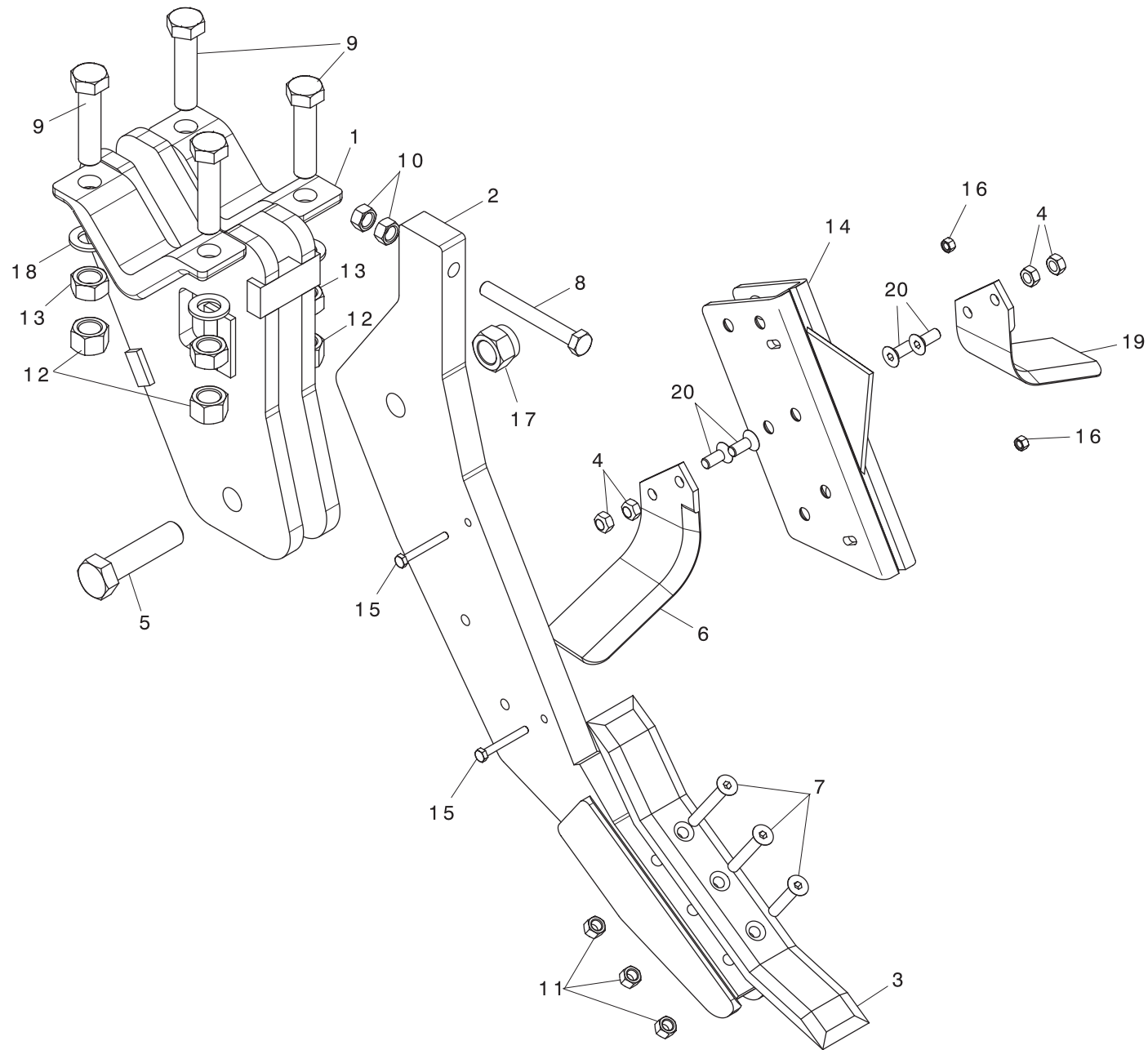

Pos.	Cod.	Descrizione	Description	Description	Benennung	Descripcion
1	17820012	SUPPORTO PUNTALE	SUPPORT FOR EARTH-OPENING BLAD	SUPPORT EMBOUT	MESSERHALTER	SOPORTE PUNTAL
2	17820191	PUNTALE	TIP	EMBOUT	STÜTZE	PUNTAL
3	67002037	DENTE PUNTALE ARTIGLIO	CLAW TIP TOOTH	DENT EMBOUT GRIFFE	ZAHN KLAUEST_TZE	DIENTE PUNTAL GARRA
4	43549004	DADO TRISTOP M12	NUT- TRISTOP M12	ECROU TRISTOP M12	MUTTER TRISTOP M12	TUERCA TRISTOP M12
5	41602192	VITE 27X110 5712 10.9 ZN	SCREW 27X110 5712 10.9 ZN	VIS 27X110 5712 10.9 ZN	SCHRAUBE 27X110 5712 10.9 ZN	TORNILLO 27X110 5712 10.9 ZN
6	67002052	ZAPPETTA VRN.NERA (MAZZI DX.)	HOE BLADE RIGHT	BINETTE DRT.	KLEINES MESSER RECHTS	SALLETE DERECHA
7	41724086	VITE 12X65 5933 8.G ZN	SCREW 12X65 5933 8.G ZN	VIS 12X65 5933 8.G ZN	SCHRAUBE 12X65 5933 8.G ZN	TORNILLO 12X65 5933 8.G ZN
8	41602098	VITE 16X140 6737 8.G ZN	BOLT 16X140 6737 8.G GALVANIZ	VIS 16X140 6737 8.G ZN	SCHRAUBE 16X140 6737 8.G ZN	TORNILLO 16X140 6737 8.G ZN
9	41602191	VITE 24X100 5737 10.9 ZN	SCREW 24X100 5737 10.9 ZN	VIS 24X100 5737 10.9 ZN	SCHRAUBE 24X100 5737 10.9 ZN	TORNILLO 24X100 5737 10.9 ZN
10	43530010	DADO 16 5588 6.8 ZN *	NUT 16 UNI 5588 6.8 GALVANIZED	ECROU 16 UNI 5588 6.8 ZN	MUTTER 16 UNI 5588 6.8 ZN	TUERCA 16 UNI 5588 6.8 ZN
11	43442007	DADO AUTOB.NOR.12 ZN	NORMAL SELF-LOCKING NUT 12 GAL	ECROU AUTOB. NOR. 12 ZN	SELBSTSP. MUTTER NOR.12 ZN	TUERCA AUTOB. NOR.12 ZN
12	43442015	DADO AUTOB.NORM.24 ZN	SELF-LOCKING NUT NORM.24 ZN	+CROU AUTOB.NORM.24 ZN	SELBSTSPERR. MUTTER NORM.24 ZN	TUERCA AUTOB .NORM.24 ZN
13	43530014	DADO 24 5588 6.8 ZN	NUT 24 5588 6.8 ZN	+CROU 24 5588 6.8 ZN	MUTTER 24 5588 6.8 ZN	TUERCA 24 5588 6.8 ZN
14	17820240	ROMPIZOLLE	CLOD-BREAKING	BRISE-MOTTES	SCHOLLENBRECHER	DESTERRONADOR
15	41602028	VITE 8 X60 5737 8.G ZN	BOLT 8 X60 5737 8.G GALVANIZED	VIS 8 X60 5737 8.G ZN	SCHRAUBE 8 X60 5737 8.G ZN	TORNILLO 8 X60 5737 8.G ZN
16	43549002	DADO TRISTOP M 8	NUT- TRISTOP M 8	ECROU TRISTOP M 8	MUTTER TRISTOP M 8	TUERCA TRISTOP M 8
17	43442014	DADO AUTOB.NORM.27 ZN	SELF-LOCKING NUT NORM.27 ZN	+CROU AUTOB.NORM.27 ZN	SELBSTSPERR. MUTTER NORM.27 ZN	TUERCA AUTOB. NORM.27 ZN
18	18701590	RONDELLA 25 x 35 x2,5 ZN	WASHER 25 x 35 x2,5 ZN	RONDELLE 25 x 35 x2,5 ZN	UNTERLEGSSCHEIBE 25 x 35 x2,5 ZN	ARANDELA 25 x 35 x2,5 ZN
19	67002053	ZAPPETTA VRN.NERA (MAZZI SX.)	HOE BLADE LEFT	BINETTE GCH.	KLEINES MESSER LINKS	SALLETE IZQUIERDA
20	41724067	VITE 12X30 5933 10.9 ZN	BOLT12X30 5933 10.9 GALVANIZED	VIS 12X30 5933 10.9 ZN	SCHRAUBE 12X30 5933 10.9 ZN	TORNILLO 12X30 5933 10.9 ZN

TAV. 980/731

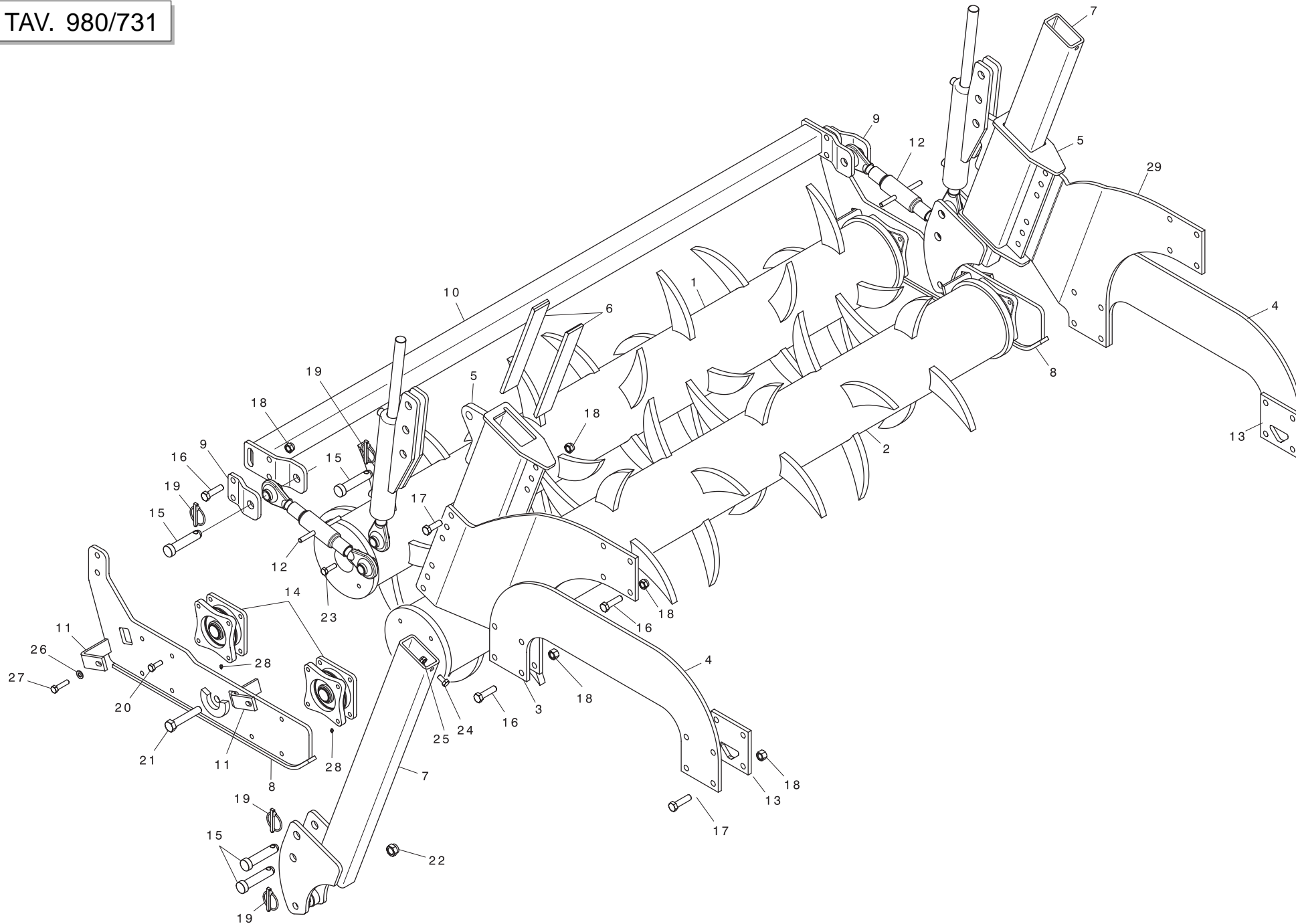

DOPPIO RULLO POSTERIORE

TAV. 980/731

Pos.	Cod.	Descrizione	Description	Description	Benennung	Descripcion
1	17811201	RULLO 40 DENTI 300	ROLLER- 40 TEETH 300	ROULEAU A 40 DENTS 300	40 ZAHN ROLLE 300	RODILLO DE 40 DIENTES 300
1	17811181	RULLO 32 DENTI 250	ROLLER- 32 TEETH 250	ROULEAU A 32 DENTS 250	32 ZAHN ROLLE 250	RODILLO DE 32 DIENTES 250
2	17811211	RULLO 36 DENTI 300	ROLLER- 36 TEETH 300	ROULEAU A 36 DENTS 300	36 ZAHN ROLLE 300	RODILLO DE 36 DIENTES 300
2	17811191	RULLO 28 DENTI 250	ROLLER- 28 TEETH 250	ROULEAU A 28 DENTS 250	28 ZAHN ROLLE 250	RODILLO DE 28 DIENTES 250
3	17812220	LAMA SUPPORTO REGOLAZIONE	SUPPORT BLADE ADJUSTMENT	SUPPORT LAME REGLAGE	HALTERUNG MESSER	CUCHILLA SOPORTE
4	17811270	LAMA DI RINFORZO	BLADE REINFORCEMENT	LAME RENFORCEMENT	MESSER VERSTZRKUNG	CUCHILLAS REFUERZO
5	17811320	SUPPORTO SCORRIMENTO RULLI	ROLLER SUPPORT SLIDING	SUPPORT DE GLISSEMENT ROULEAU	HALBGLEITHALTERUNG	SOPORTE DE DESPLAZAMIENTO
6	17811331	LAMA DI SCORRIMENTO	BLADE SLIDING	LAME DE GLISSEMENT	GLEITMESSER	CUCHILLAS DE DESPLAZAMIENTO
7	17811370	LEVA SCORRIMENTO RULLI	LEVER SLIDING	LEVIER DE GLISSEMENT	GLEITHEBEL	PALANCA DE DESPLAZAMIENTO
8	17811401	SUPPORTO RULLO	ROLLER SUPPORT	SUPPORT ROULEAUX	RIEMENSPANNERROLLEN	SOPORTE RODILLOS
9	17811410	LAMA DI ATTACCO	BLADE	LAME	MESSER	CUCHILLA
10	17811611	PROTEZIONE	GUARD	PROTECTION	SCHUTZ	PROTECCIÓN
10	17811431	PROTEZIONE	GUARD	PROTECTION	SCHUTZ	PROTECIÓN
11	17811450	RASCHIATERRA	SOIL SCRAPER	RACLEUR	ERDSCHABER	RASCADOR DE TIERRA
12	17811490	TIRANTE TERZO PUNTO	3° POINT TIE ROD	TRINGLE 3° POINT	SPANNSTANGE 3° PUNKT	TIRANTE 3° PUNTO
13	17810160	SCONTRO 145X145	STRIKER PLATE 145X145	BUTEE 145X145	ANSCHLAG 145X145	ELEMENTO DE EMPALME 145X145
14	17014180	SUPPORTO CUSCINETTO	BEARING SUPPORT	SUPPORT ROULEMENT	LAGERHALTERUNG	SOPORTE COJINETE
15	15412410	SPINA GASPARDO 25X97	GASPARDO PIN 25X97	BROCHE GASPARDO 25X97	STIFT GASPARDO 25X97	CLAVIJA GASPARDO 25X97
16	41602087	VITE 16X60 5737 8.G ZN	BOLT 16X60 5737 8.G GALVANIZED	VIS 16X60 5737 8.G ZN	SCHRAUBE 16X60 5737 8.G ZN	TORNILLO 16X60 5737 8.G ZN
17	41602085	VITE 16X50 5737 8.G ZN	SCREW 16X50 5737 8.G GALVANIZ	VIS 16X50 5737 8.G ZN	SCHRAUBE 16X50 5737 8.G ZN	TORNILLO 16X50 5737 8.G ZN
18	43442009	DADO AUTOB.NOR.16 ZN	NORMAL SELF-LOCKING NUT 16 GAL	ECROU AUTOB. NOR. 16 ZN	MUTTER AUTOB.NOR.16 ZN	TUERCA AUTOB. NOR.16 ZN
19	45965007	SPINA A SCATTO D 9 B/83	SNAP PIN D 9 B/83	FICHE A DETENTE D. 9 B/83	EINRASTSTIFT D 9 B/83	CLAVIJA DE MUELLE D 9 B/83
20	41607022	VITE 12X1,25X35 5740 8.8 ZN	SCREW 12X1.25X35 5740 8.8 ZN	VIS 12X1,25X35 5740 8.8 ZN	SCHRAUBE 12X1,25X35 5740 8.8 Z	TORNILLO 12X1,25X35 5740 8.8 Z
21	41602116	VITE 20X110 5737 8.G ZN	BOLT 20X110 5737 8.G GALVANIZ.	VIS 20X110 5737 8.G ZN	SCHRAUBE 20X110 5737 8.G ZN	TORNILLO 20X110 5737 8.G ZN
22	43442011	DADO AUTOB.NOR.20 ZN	NORMAL SELF-LOCKING NUT 20 GAL	ECROU AUTOB. NOR. 20 ZN	MUTTER AUTOB.NOR.20 ZN	TUERCA AUTOB. NOR.20 ZN
23	41724084	VITE 12X40 5739 10.9 ZN	SCREW 12X40 5739 10.9 ZN	VIS 12X40 5739 10.9 ZN	SCHRAUBE 12X40 5739 10.9 ZN	TORNILLO 12X40 5739 10.9 ZN
24	41605049	VITE 12X25 5739 8.G ZN	SCREW 12X25 5739 8.G GALVANIZ.	VIS 12X25 5739 8.G ZN	SCHRAUBE 12X25 5739 8.G ZN	TORNILLO 12X25 5739 8.G ZN
25	43442007	DADO AUTOB.NOR.12 ZN	NORMAL SELF-LOCKING NUT 12 GAL	ECROU AUTOB. NOR. 12 ZN	SELBSTSP. MUTTER NOR.12 ZN	TUERCA AUTOB. NOR.12 ZN
26	44953005	RONDELLA D12 UNI 6592 ZN	WASHER D12 UNI 6592 ZN	RONDELLE D12 UNI 6592 ZN	UNTERLEGSSCHEIBE D12 UNI 6592 Z	ARANDELA D12 UNI 6592 ZN
27	41607023	VITE 12X1,25 X45 5740 8.8 ZN	SCREW 12X1.25X45 5740 8.8 ZN	VIS 12X1,25X45 5740 8.8 ZN	SCHRAUBE 12X1,25X45 5740 8.8 Z	TORNILLO 12X1,25X45 5740 8.8 Z
28	47969001	INGRASS.A SFERE M6X1/A	SPHERE NIPPLE M6X1/A	GRAISSEUR A BILLES M6X1/A	KUGELFETTBSCHSE M6X1/A	ENGRAS. DE ESFERAS M6X1/A
29	17812230	LAMA SUPPORTO REGOLAZIONE	SUPPORT BLADE ADJUSTMENT	SUPPORT LAME REGLAGE	HALTERUNG MESSER	CUCHILLA SOPORTE

TAV. 980/740

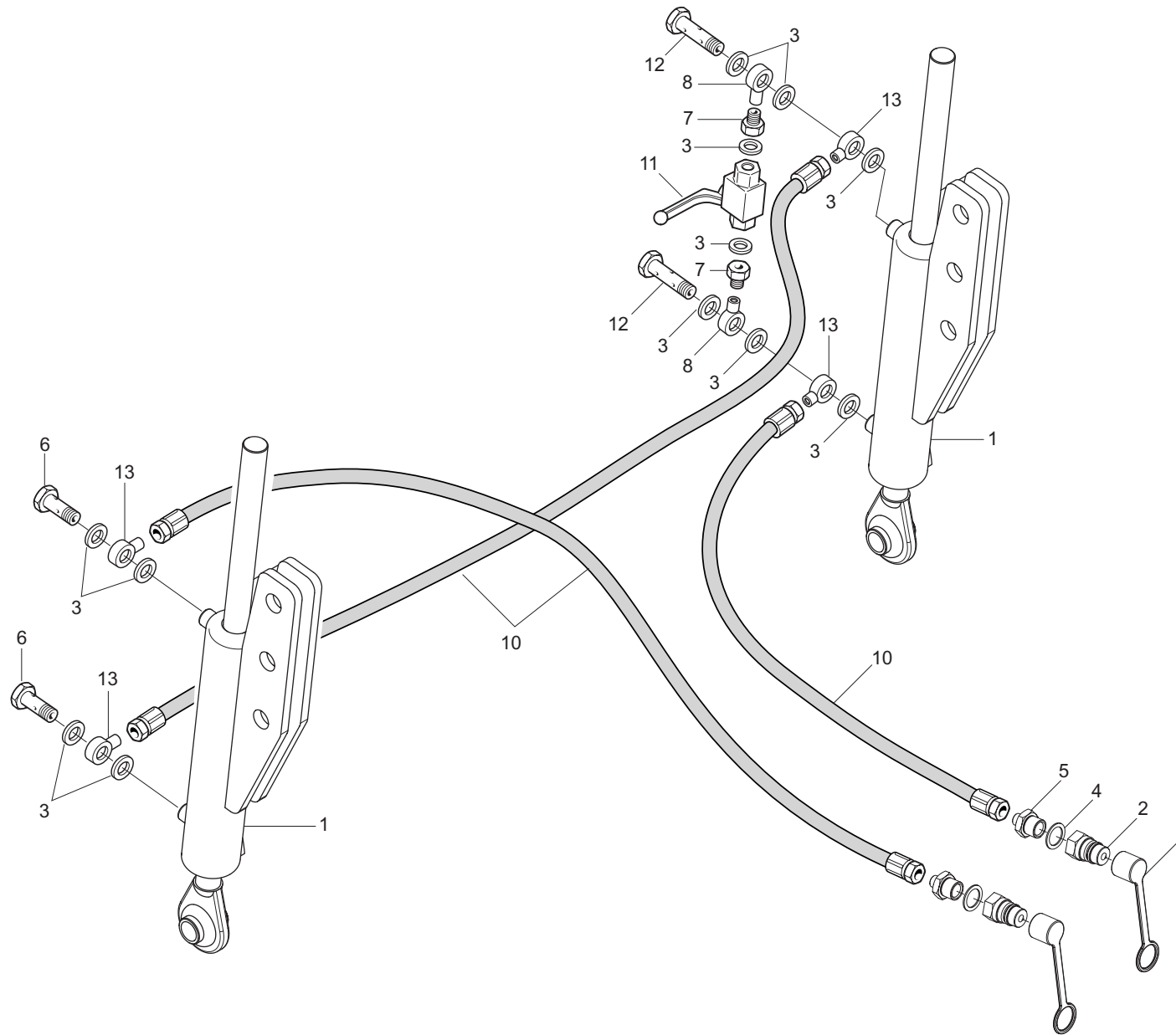

IMPIANTO OLEODINAMICO RULLI POSTERIORI
TAV. 980/740

Pos.	Cod.	Descrizione	Description	Description	Benennung	Descripcion
1	17811480	CILINDRO 30X70 - 280	CYLINDER 30X70 - 280	CYLINDRE 30X70 - 280	ZYLINDER 30X70 - 280	CILINDRO 30X70 - 280
2	67007210	INNESTO RAPIDO MASCH.CONO 1/2	QUICK CONNECT MALE CONE 1/2 CO	CONNEXION RAPIDE MALE CONE 1/2	SCHNELLKUPPLUNG GEWINDE KONISC	ACOPLAMIENTO Rápido MACHO CONO
3	67007242	RONDELLA RAME 3/8	3/8 COPPER WASHER	RONDELLE CUIVRE 3/8	UNTERLEGSCHEIBE KUPFER 3/8	ARANDELA COBRE 3/8
4	67007243	RONDELLA RAME 1/2	1/2 COPPER WASHER	RONDELLE CUIVRE @	UNTERLEGSCHEIBE KUPFER 1/2	ARANDELA COBRE 1/2
5	67007291	NIPPLO MASCH.CIL.1/2-1/4 ZN	NIPPLE- GALVAN. CYLINDR.MALE-	NIPPLE MALE CYL. 1/2-1/4 ZN	NIPPELZYL.1/2-1/4 ZN	NIPLE MACHO CIL.1/2-1/4 ZN
6	67007415	RACCORDO VITE CAVA 3/8	UNION BOLT HOLLOW 3/8	RACCORD VIS CREUSE 3/8	ANSCHLUSS GEWINDEHOHLSCHR.3/8	UNIN TORNILLO RANURA 3/8 R
7	67007437	GIUNZ.DIRITTA FIL.CIL.3/8-12LR	STRAIGHT JOIN THREAD. CYL.3/8-	JONCT. DROITE FIL. CYL. 3/8-12	GER. KUPPLUNG ZYL. 3/8-12LR	ACOPLAM. RECTO FIL.CIL.3/8-1
8	67007480	RACCORDO OCCHIO 3/8 L.220	EYE UNION 3/8 L.200	RACCORD OEIL 3/8 L.200	TSENVERBINDUNGSSTsCK 3/8 I.200	UNIN OJO 3/8 L.200
9	67008034	CAPPUCCIO INNESTO 1/2	CONNECTION CAP NUT 1/2	CAPUCHON ACCOUPLEMENT 1/2	HAUBE KUPPLUNG 1/2	CAPUCHON ACOPLAMIENTO 1/2
10	14214131	TUBO 1/4R2 CF1/4-F1/4 L.5300	PIPE 1/4R2 CF1/4-F1/4 L.5300	TUBE 1/4R2 CF1/4-F1/4 L.5300	ROHR 1/4R2 CF1/4-F1/4 L.5300	TUBO 1/4R2 CF1/4-F1/4 L.5300
11	67321106	RUBINETTO F-F 3/8	BREATHER TAP F-F 3/8	BOUCHON REFOUL. F-F 3/8	ENTLsFTUNGSPFROPFEN F-F 3/8	TAPON PURGADOR F-F 3/8
12	67321107	RACCORDO VITE CAVA 3/8 8 FORI	UNION BOLT HOLLOW 3/8	RACCORD VIS CREUSE 3/8	ANSCHLUSS GEWINDEHOHLSCHR.3/8	UNIN TORNILLO RANURA 3/8 R
13	67321108	RACCORDO VITE CAVA 3/8 - 1/4	UNION BOLT HOLLOW 3/8 - 1/4	RACCORD VIS CREUSE 3/8 - 1/4	ANSCHLUSS GEWINDEHOHLSCHR.3/8-1/4	UNIN TORNILLO RANURA 3/8 - 1/4

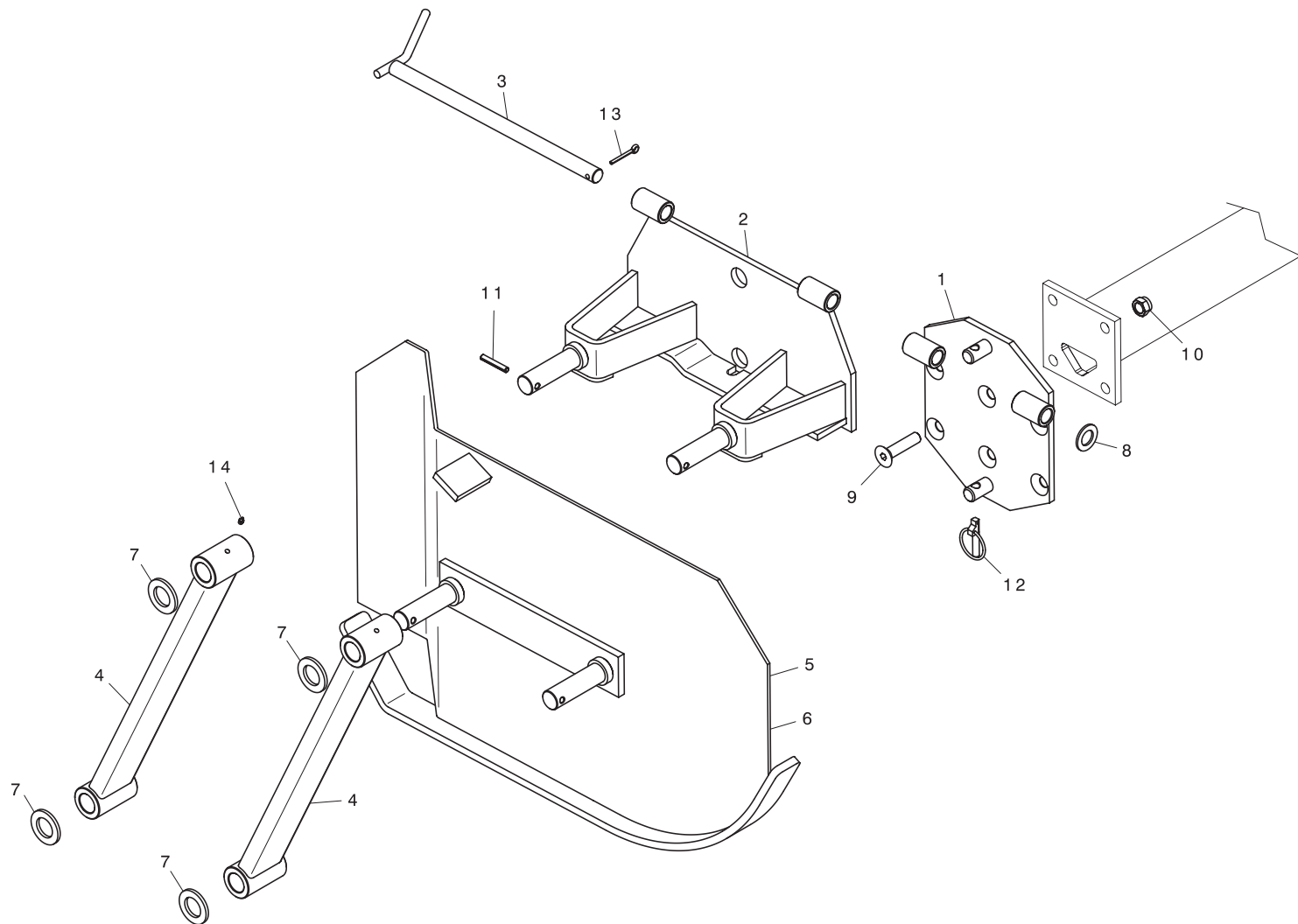

BANDINELLE LATERALI

TAV. 980/751

Pos.	Cod.	Descrizione	Description	Description	Benennung	Descripcion
1	17811650	PIASTRA DI ATTACCO	FIXING PLATE	PLAQUE DE RACCORD	KUPPLUNGSPLATTE	PLACA DE CONEXIN
2	17811710	RIBALTAMENTO BANDELLE	SUPPORT	SUPPORT	HALTERUNG	SOPORTE
3	17811730	PERNO ZN	PIN ZN	PIVOT ZN	BOLZEN ZN	PERNO ZN
4	17811760	LEVA	LEVER	LEVIER	HEBEL	PALANCA
5	17811821	BANDELLA SX	PROTECTION SX	PROTECTION SX	SCHUTZ SX	PROTECCIÓN SX
6	17811831	BANDELLA DX	PROTECTION DX	PROTECTION DX	SCHUTZ DX	PROTECCIÓN DX
7	20970067	RONDELLA 54X5X32	WASHER 54X5X32	RONDELLE 54X5X32	UNTERLEGSSCHEIBE 54X5X32	ARANDELA 54X5X32
8	22500125	RONDELLA DI FERMO	STOP WASHER	RONDELLE D'ARRET	FESTSTELLSCHEIBE	ARANDELA DE BLOQUEO
9	41724089	VITE 16X70 5933 8.G ZN	BOLT 16X70 5933 8.G GALVANIZED	VIS 16X70 5933 8.G ZN	SCHRAUBE 16X70 5933 8.G ZN	TORNILLO 16X70 5933 8.G ZN
10	43442009	DADO AUTOB.NOR.16 ZN	NORMAL SELF-LOCKING NUT 16 GAL	ECROU AUTOB. NOR. 16 ZN	MUTTER AUTOB.NOR.16 ZN	TUERCA AUTOB. NOR.16 ZN
11	46966130	SPINA EL.8X50 DIN 1481	PIN EL. .8 X50 DIN 1481	FICHE EL.8 X50 DIN 1481	SPANNSTIFT 8 X50 DIN 1481	CLAVIJA EL.8 X50 DIN 1481
12	45965007	SPINA A SCATTO D 9 B/83	SNAP PIN D 9 B/83	FICHE A DETENTE D. 9 B/83	EINRASTSTIFT D 9 B/83	CLAVIJA DE MUELLE D 9 B/83
13	45961081	COPIGLIA 5 X20 1336 ZN	SPLIT PIN 5 X20 1336 GALVAN.	GOUPILLE 5 X20 1336 ZN	SPLINT 5 X20 1336 ZN	PASADOR 5 X20 1336 ZN
14	47969003	INGRASS.A SFERE M8 X 1,25 A	SPHRE NIPPLE M8 X 1-25 A	GRAISSEUR A BILLES M8 X 1-25 A	KUGELFETTBSCHSE M8 X 1-25 A	ENGRAS. DE ESFERAS M8 X 1-25 A

TAV. 980/760

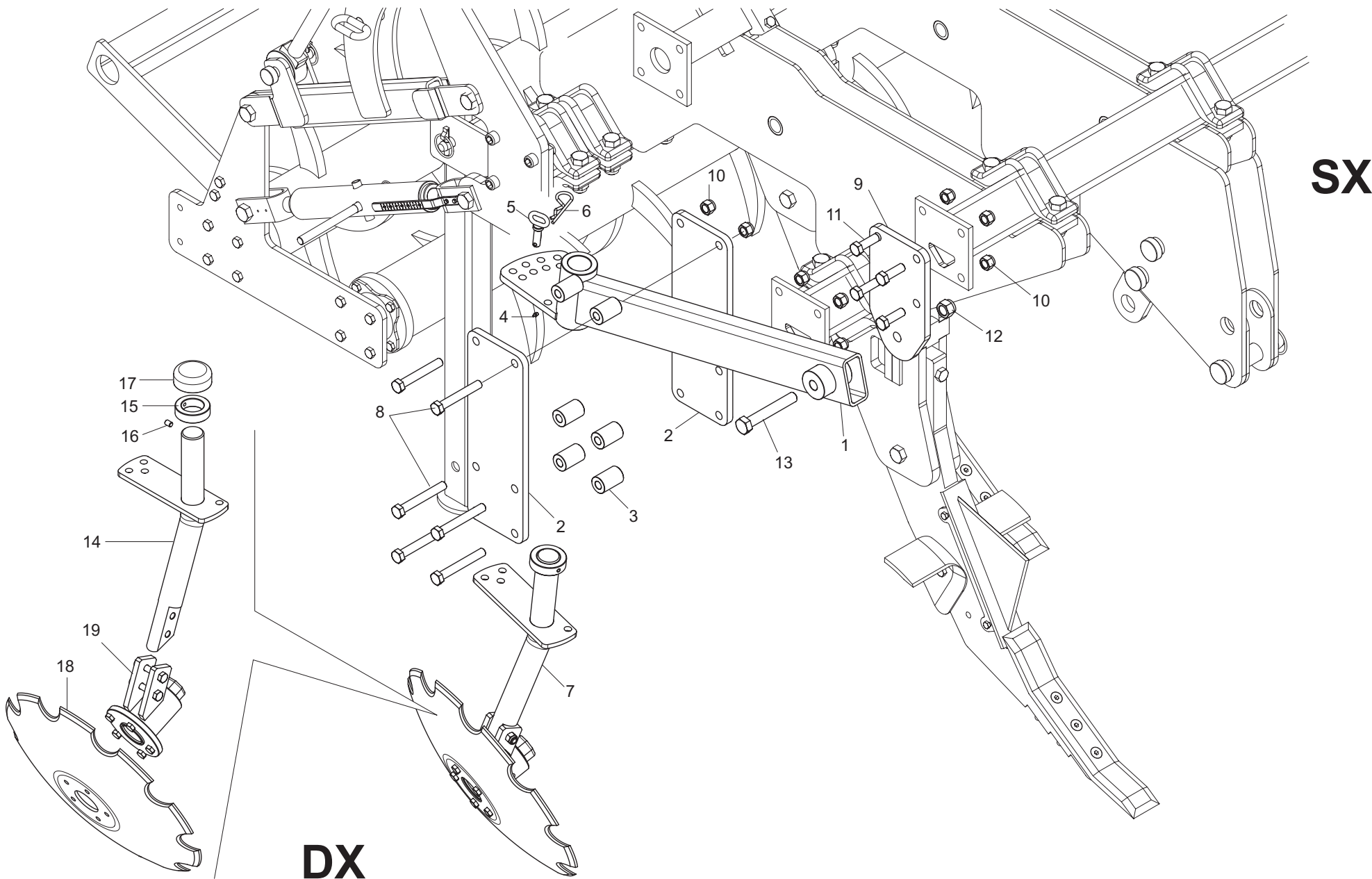

DISCHI DI CONTENIMENTO

TAV. 980/760

Pos.	Cod.	Descrizione	Description	Description	Benennung	Descripcion
1	17810900	SUPPORTO DISCO DX	DISC SUPPORT DX	SUPPORT DISQUE DX	SCHEIBENHALTERUNG DX	SOPORTE DISCO DX
1	17810940	SUPPORTO DISCO SX	DISC SUPPORT SX	SUPPORT DISQUE SX	SCHEIBENHALTERUNG SX	SOPORTE DISCO SX
2	17810820	LAMA REGOLAZIONE FINECORSIA	TRAVEL STOP BRACKET	BRIDE FIN DE COURSE	BsGEL ENDANSCHLAG	ESTR. FINAL DE CARRERA
3	17810880	BOCCOLA 16,5 X35 X52 ZN	BUSHING 16,5 X35 X52 ZN	BOITE 16,5 X35 X52 ZN	BsCHSE 16,5 X35 X52 ZN	CASQUILLO 16,5 X35 X52 ZN
4	47969001	INGRASS.A SFERE M6X1/A	SPHERE NIPPLE M6X1/A	GRAISSEUR A BILLES M6X1/A	KUGELFETTBSCHSE M6X1/A	ENGRAS. DE ESFERAS M6X1/A
5	17810970	SPINA ZN	PIN ZN	GOUVILLE ZN	BOLZENSTIFT ZN	PASADOR ZN
6	45963006	COPIGLIA R 5X100 ZN	SPLIT PIN R 5X100 GALVANIZED	GOUVILLE R 5X100 ZN	SPLINT R 5X100 ZN	PASADOR R 5X100 ZN
7	17811120	DISCO CONTENIMENTO DX COMPL.	DISK ASSY. DX	DISQUE COMPL. DX	KOMPLETTE SCHEIBE DX	DISCO COMPLETO DX
7	17811130	DISCO CONTENIMENTO SX COMPL.	DISK ASSY. SX	DISQUE COMPL. SX	KOMPLETTE SCHEIBE SX	DISCO COMPLETO SX
8	41602095	VITE 16X120 5737 8.G ZN	BOLT 16X120 5737 8.G GALVANIZ	VIS 16X120 5737 8.G ZN	SCHRAUBE 16X120 5737 8.G ZN	TORNILLO 16X120 5737 8.G ZN
9	17810810	LAMA AGGANCIAMENTO TUBO	TUBE COUPLER	ATTELAGE TUBE	KUPPLUNG ROHR	ENGANCHE TUBO
10	43442009	DADO AUTOB.NOR.16 ZN	NORMAL SELF-LOCKING NUT 16 GAL	ECROU AUTOB. NOR. 16 ZN	MUTTER AUTOB.NOR.16 ZN	TUERCA AUTOB. NOR.16 ZN
11	41602085	VITE 16X50 5737 8.G ZN	SCREW 16X50 5737 8.G GALVANIZ	VIS 16X50 5737 8.G ZN	SCHRAUBE 16X50 5737 8.G ZN	TORNILLO 16X50 5737 8.G ZN
12	43442011	DADO AUTOB.NOR.20 ZN	NORMAL SELF-LOCKING NUT 20 GAL	ECROU AUTOB. NOR. 20 ZN	MUTTER AUTOB.NOR.20 ZN	TUERCA AUTOB. NOR.20 ZN
13	41602119	VITE 20X130 5737 8.8 ZN	SCREW 20X130 5737 8.8 GALVAN.	VIS 20X130 5737 8.8 ZN	SCHRAUBE 20X130 5737 8.8 ZN	TORNILLO 20X130 5737 8.8 ZN
14	17811080	BRACCIO SUPPORTO DISCO SX	DISC ARM SUPPORT	SUPPORT BRAS DISQUE	HALTERUNG SCHEIBENARM	SOPORTE BRAZO DISCO
15	67002048	BOCCOLA DI BLOCCO	BLOCK BUSHING	BOITE DE ENSEMBLE	BLOCKBSCHSE	CASQUILLO DE BLOQUE
16	67002049	GRANO	GRUB--SCREW	GOUJON	STIFT	TORNILLO SIN CABEZA
17	67002047	TAPPO	CLOSURE TAP	BOUCHON DE FERMETURE	ABSCHLUSSPFROPFEN	TAPN DE CIERRE
18	67002046	DISCO DENTATO	TOOTHED DISK	DISQUE DENTE	VERZAHNTE SCHEIBE	DISCO DENTADO
19	67002045	SUPPORTO CUSCINETTI	BEARING SUPPORT	SUPPORT PALIER	LAGERBUCHSE	SOPORTE COJINETE

TAV. 980/770

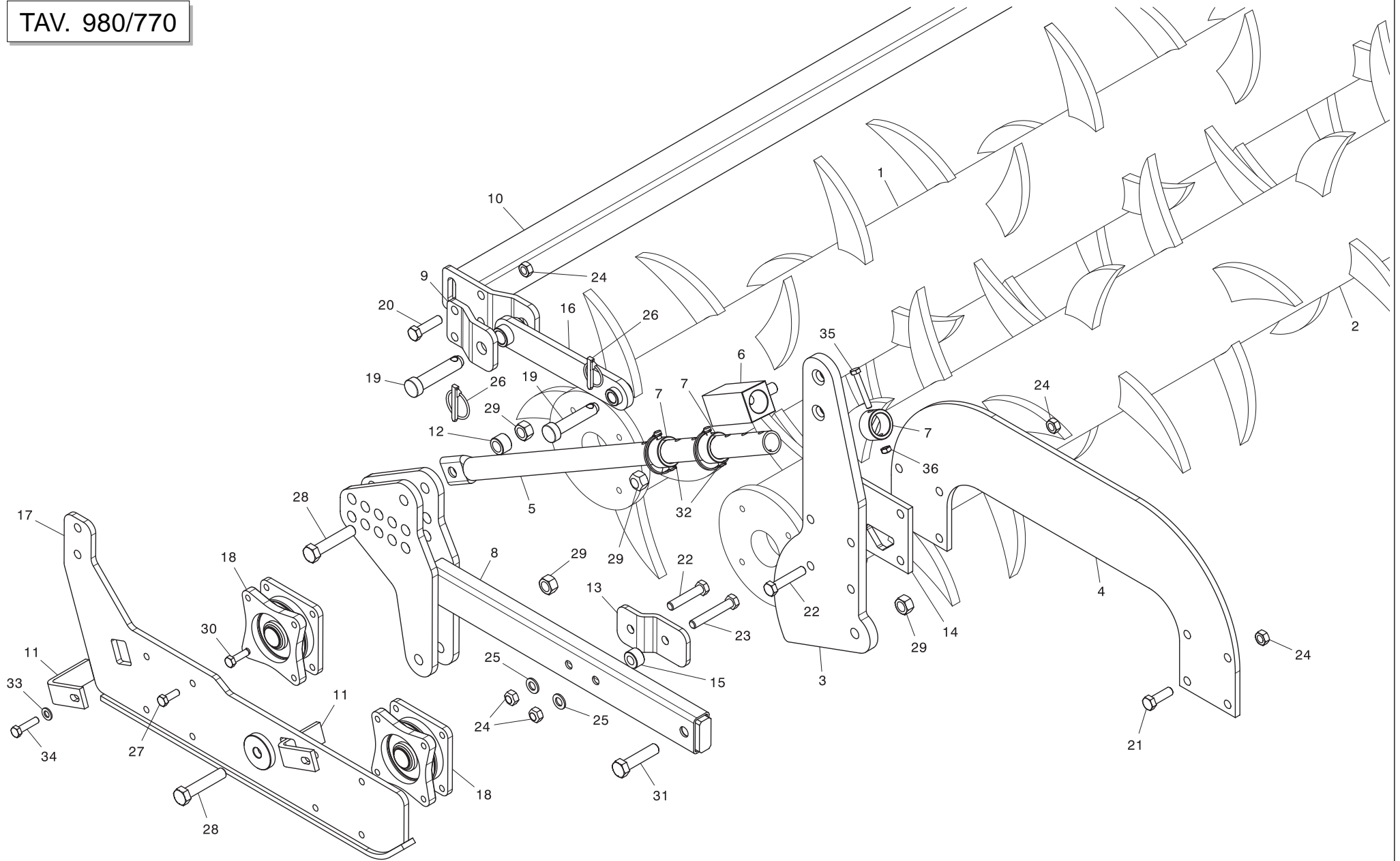

REGOLAZIONE MECCANICA RULLI

TAV. 980/770

Pos.	Cod.	Descrizione	Description	Description	Benennung	Description
1	17811181	RULLO 32 DENTI 250	ROLLER- 32 TEETH 250	ROULEAU A 32 DENTS 250	32 ZAHN ROLLE 250	RODILLO DE 32 DIENTES 250
2	17811191	RULLO 28 DENTI 250	ROLLER- 28 TEETH 250	ROULEAU A 28 DENTS 250	28 ZAHN ROLLE 250	RODILLO DE 28 DIENTES 250
3	17811900	LAMA SUPPORTO RULLI	BLADE SUPPORT ROLLER	LAME DE SUPPORT ROULEAUX	RIEMENSPANNERROLLEN MESSER	PALANCA DE SOPORTE RODILLOS
4	17811270	LAMA DI RINFORZO	BLADE REINFORCEMENT	LAME RENFORCEMENT	MESSER VERSTZRKUNG	CUCHILLAS REFUERZO
5	17811910	TUBO REGOLAZIONE	ADJUSTMENT TUBE	TUBE REGLAGE	ROHR EINSTELLUNG	TUBO REGULACIN
6	17811950	TUBO REGOLAZIONE ZN	ADJUSTMENT TUBE ZN	TUBE REGLAGE ZN	ROHR EINSTELLUNG ZN	TUBO REGULACIN ZN
7	17811960	BOCCOLA PER REGOLAZIONE ZN	BUSHING ADJUSTMENT ZN	BOITE REGLAGE ZN	EINSTELLBsCHSE ZN	CASQUILLO REGULACIN ZN
8	17811881	LEVA	LEVER	LEVIER	HEBEL	PALANCA
9	17811410	LAMA DI ATTACCO	BLADE	LAME	MESSER	CUCHILLA
10	17811431	PROTEZIONE	GUARD	PROTECTION	SCHUTZ	PROTECIÉN
11	17811450	RASCHIATERRA	SOIL SCRAPER	RACLEUR	ERDSCHABER	RASCADOR DE TIERRA
12	17812000	BOCCOLA 21,7X33,7X23 ZN	BUSHING 21,7X33,7X23 ZN	BOITE 21,7X33,7X23 ZN	BsCHSE 21,7X33,7X23 ZN	CASQUILLO 21,7X33,7X23 ZN
13	17812010	LAMA DI GUIDA	BLADE GUIDE	LAME GUIDE	MESSER FSHRUNG	CUCHILLA GUA
14	17810160	SCONTRIO 145X145-12 4F17 105	STRIKER PLATE 145X145	BUTEE 145X145	ANSCHLAG 145X145	ELEMENTO DE EMPALME 145X145
15	17812020	BOCCOLA 17X34X20 ZN	BUSHING 17X34X20 ZN	BOITE 17X34X20 ZN	BsCHSE 17X34X20 ZN	CASQUILLO 17X34X20 ZN
16	17812161	LEVAANGOLO	LEVER	LEVIER	HEBEL	PALANCA
17	17812170	SUPPORTO RULLO MECCANICO	ROLLER SUPPORT	SUPPORT ROULEAUX	RIEMENSPANNERROLLEN	SOPORTE RODILLOS
18	17014180	SUPPORTO CUSCINETTO	BEARING SUPPORT	SUPPORT ROULEMENT	LAGERHALTERUNG	SOPORTE COJINETE
19	15412410	SPINA GASPARDO 25X97	GASPARDO PIN 25X97	BROCHE GASPARDO 25X97	STIFT GASPARDO 25X97	CLAVIJA GASPARDO 25X97
20	41602087	VITE 16X60 5737 8.G ZN	BOLT 16X60 5737 8.G GALVANIZED	VIS 16X60 5737 8.G ZN	SCHRAUBE 16X60 5737 8.G ZN	TORNILLO 16X60 5737 8.G ZN
21	41602085	VITE 16X50 5737 8.G ZN	SCREW 16X50 5737 8.G GALVANIZ	VIS 16X50 5737 8.G ZN	SCHRAUBE 16X50 5737 8.G ZN	TORNILLO 16X50 5737 8.G ZN
22	41602090	VITE 16X80 5737 8.8 ZN	BOLT 16X80 5737 8.G GALVANIZ.	VIS 16X80 5737 8.G ZN	SCHRAUBE 16X80 5737 8.G ZN	TORNILLO 16X80 5737 8.G ZN
23	41602194	VITE 16X100 5737 8.G ZN	BOLT 16X100 5737 8.G GALVANIZ	VIS 16X100 5737 8.G ZN	SCHRAUBE 16X100 5737 8.G ZN	TORNILLO 16X100 5737 8.G ZN
24	43442009	DADO AUTOB.NOR.16 ZN	NORMAL SELF-LOCKING NUT 16 GAL	ECROU AUTOB. NOR. 16 ZN	MUTTER AUTOB.NOR.16 ZN	TUERCA AUTOB. NOR.16 ZN
25	44953007	RONDELLA D16 UNI 6592 ZN	WASHER D16 UNI 6592 ZN	RONDELLE D16 UNI 6592 ZN	UNTERLEGSSCHEIBE D16 UNI 6592 Z	ARANDELA D16 UNI 6592 ZN
26	45965007	SPINA A SCATTO D 9 B/83	SNAP PIN D 9 B/83	FICHE A DETENTE D. 9 B/83	EINRASTSTIFT D 9 B/83	CLAVIJA DE MUELLE D 9 B/83
27	41607022	VITE 12X1,25X35 5740 8.8 ZN	SCREW 12X1,25X35 5740 8.8 ZN	VIS 12X1,25X35 5740 8.8 ZN	SCHRAUBE 12X1,25X35 5740 8.8 Z	TORNILLO 12X1,25X35 5740 8.8 Z
28	41602115	VITE 20X100 5737 8.G ZN	BOLT 20X100 5737 8.G GALVANIZ.	VIS 20X100 5737 8.G ZN	SCHRAUBE 20X100 5737 8.G ZN	TORNILLO 20X100 5737 8.G ZN
29	43442011	DADO AUTOB.NOR.20 ZN	NORMAL SELF-LOCKING NUT 20 GAL	ECROU AUTOB. NOR. 20 ZN	MUTTER AUTOB.NOR.20 ZN	TUERCA AUTOB. NOR.20 ZN
30	41724084	VITE 12X40 5739 10.9 ZN	SCREW 12X40 5739 10.9 ZN	VIS 12X40 5739 10.9 ZN	SCHRAUBE 12X40 5739 10.9 ZN	TORNILLO 12X40 5739 10.9 ZN
31	41602166	VITE 20X90 5737 10.9 ZN	BOLT 20X90 5737 10.9G GALVANI	VIS 20X90 5737 10.9G ZN	SCHRAUBE 20X90 5737 10.9G ZN	TORNILLO 20X90 5737 10.9G ZN
32	45965013	SPINA DI SICUREZZA D.12X70 ZN	GALVAN. SAFETY PIN D.12X70	GOUPILLE DE S+CURIT+ D.12X70 Z	SCHERSTIFT D.12X70 ZN	PASADOR DE SEGURIDAD 12X70 Z
33	44953002	RONDELLA D6 UNI 6592 ZN	WASHER D6 UNI 6592 GALVANIZED	RONDELLE D6 UNI 6592 ZN	UNTERLEGSSCHEIBE D6 UNI 6592 ZN	ARANDELA D6 UNI 6592 ZN
34	41607023	VITE 12X1,25 X45 5740 8.8 ZN	SCREW 12X1,25X45 5740 8.8 ZN	VIS 12X1,25X45 5740 8.8 ZN	SCHRAUBE 12X1,25X45 5740 8.8 Z	TORNILLO 12X1,25X45 5740 8.8 Z
35	41602044	VITE 10X70 5737 8.G ZN	BOLT10X70 5737 8.G GALVANIZED	VIS 10X70 5737 8.G ZN	SCHRAUBE 10X70 5737 8.G ZN	TORNILLO 10X70 5737 8.G ZN
36	43442006	DADO AUTOB.NOR.10 ZN	NORM.SELF-LOCKING NUT 10 GALVA	ECROU AUTOB.NOR.10 ZN	SELBSTSP. MUTTER NOR. 10 ZN	TUERCA AUTOB. NOR. 10 ZN

**USATE SEMPRE RICAMBI ORIGINALI
ALWAYS USE ORIGINAL SPARE PARTS
IMMER DIE ORIGINAL-ERSATZTEILE VERWENDEN
EMPLOYEZ TOUJOURS LES PIECES DE RECHANGE ORIGINALES
UTILIZAR SIEMPRE REPUESTOS ORIGINALES**

GASPARDO

DEALER:

GASPARDO

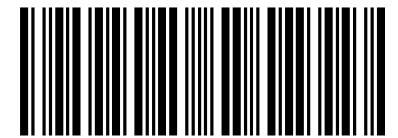

19530481

GASPARDO Seminatrici SpA
Via Mussons, 7 - I - 33075
Morsano al Tagliamento (PN) Italy
Tel. +39 0434 695410
Fax +39 0434 695425
e-mail: gaspardo@gaspardo.it
<http://www.gaspardo.it>

MASCHIO DEUTSCHLAND GMBH
Äußere Nürnberger Straße 5
D - 91177 Thalmässing
Deutschland
Tel. +49 (0) 9173 79000
Fax +49 (0) 9173 790079

MASCHIO FRANCE Sarl
1, Rue de Mérignan ZA
F - 45240 La Ferte St. Aubin
France
Tel. +33 (0) 2.38.64.12.12
Fax +33 (0) 2.38.64.66.79

MASCHIO IBERICA S.L.
Calle Cabernet, 10
Poligono Industrial Clot de Moja
Olerdola - 08734 Barcelona
Tel. +34 93.81.99.058
Fax +34 93.81.99.059

MASCHIO USA
432 2ND Street
Rock Island, IL 61201 USA
Ph. +1 309 794-2310
Fax +1 309 788-1610

MASCHIO MIDDLE EAST S.L.
MASCHIO-GASPARDO ROMANIA S.R.L.
GASPARDO-MASCHIO TURCHIA
MASCHIO-GASPARDO CANADA Inc